

# Ball valve

## Process and instrument version

### Model BV

WIKA data sheet AC 09.28



for further approvals  
see page 7

#### Applications

- Oil and gas industry, chemical and petrochemical industries, power plants
- First shut-off valve for pressure tap to local instrument installation, media distribution, drain or vent pipelines
- Direct connection of pressure measuring instruments to pipelines or vessels
- For gaseous, liquid, aggressive and highly viscous media, also in aggressive environments

#### Special features

- High-quality machining guarantees smooth operation with low torque and low wear
- Leak-tested tightness in accordance with BS6755 / ISO 5208 leakage rate A
- Large selection of materials and configurations available
- Customer-specific combination of valves and instruments (hook-up) on request

#### Description

The simple and robust design enables model BV ball valves a wide spectrum of use. The process version of the ball valve has been designed to meet the requirements of the process industry, in particular for natural gas and aggressive media applications.

For applications with liquid or gaseous media, ball valves are recommended due to easy cleaning of the straight-through internal bore.

The process version of model BV can be installed directly in the process pipeline due to complied specifications. The instrument version, on the other hand, is used as an additional shut-off valve in combination with the instrument.



**Fig. left: Model BV, process version, square design**

**Fig. right: Model BV, instrument version, round design**

The valve design and the high-quality sealing materials ensure high durability and tightness.

The ball valve can be mounted, depending on the installation conditions, directly onto a pipeline or in a control panel, or for the connection of several measuring instruments at the same location.

The super-finished machining of the internal parts allows a very smooth and precise operation, even at high pressures and after long periods without valve operation. The surface finish is also minimising corrosion with aggressive media and makes it easier to clean.

# Specifications

Model BV	
<b>Standards used</b>	
Design	<ul style="list-style-type: none"> <li>■ ASME BPVC section VIII, rules for construction of pressure vessels division 1</li> <li>■ ASME B31.1, power piping</li> <li>■ ASME B31.3, process piping</li> <li>■ ISO 17292, metal ball valves for petroleum, petrochemical and allied industries</li> <li>■ ASME B16.5, pipe flanges and flange fittings</li> <li>■ ASME B1.20.1, pipe threads, general purpose (inch)</li> </ul>
Tests	<ul style="list-style-type: none"> <li>■ API 598, valve inspection and testing</li> <li>■ ISO 5208, pressure testing of metallic valves with leakage rate A</li> <li>■ MSS SP-61, pressure testing of valves</li> <li>■ DIN EN 12266-1, pressure tests, test procedures and acceptance criteria for industrial valves</li> </ul>
Instrument version	<ul style="list-style-type: none"> <li>■ MSS SP-99, valves for measuring instruments</li> </ul>
Process version	<ul style="list-style-type: none"> <li>■ ASME B16.34, valves - flanged, threaded and welding end</li> <li>■ API 607, ISO 10497, BS 6755-2, type test for fire safety</li> <li>■ ISO15848-1, Measurement, test and qualification procedures for fugitive emissions</li> </ul>
Material requirements	<ul style="list-style-type: none"> <li>■ NACE MR0175 / ISO 15156, use in H<sub>2</sub>S-containing environments in oil and gas production</li> <li>■ NORSOK M-630, specification for use in pipelines (Norway)</li> </ul>
Marking	MSS SP-25, standard marking system for valves
<b>Version</b> (see from page 4)	
Instrument version	<ul style="list-style-type: none"> <li>■ Round design</li> <li>■ Square design</li> </ul>
Process version	<ul style="list-style-type: none"> <li>■ Square design</li> <li>■ Multiport design</li> </ul>
<b>Nominal pressure</b> <sup>1)</sup>	<ul style="list-style-type: none"> <li>■ 6,000 psi [413 bar]</li> <li>■ 10,000 psi [690 bar]</li> </ul>
<b>Nominal pipe size (DN)</b> <sup>1)</sup>	<ul style="list-style-type: none"> <li>■ ¼"</li> <li>■ ⅜"</li> <li>■ ½"</li> <li>■ ¾"</li> <li>■ 1"</li> </ul>
<b>Valve bore size</b> <sup>1)</sup>	<ul style="list-style-type: none"> <li>■ 10 mm [0.394 in]</li> <li>■ 20 mm [0.787 in]</li> </ul>
<b>Pressure-temperature limits (for diagram, see page 6)</b>	The limits for operating pressure and temperature depend on the version and the sealing material.
<b>Connection type</b>	<ul style="list-style-type: none"> <li>■ Threaded connection per ISO 228-1, code G</li> <li>■ Threaded connection per ANSI / ASME B1.20.1, code NPT</li> <li>■ Connection for welded sleeve</li> <li>■ Connection for butt weld connection</li> <li>■ Smooth pipe end</li> <li>■ Compression fitting</li> </ul>
<b>Features</b>	<ul style="list-style-type: none"> <li>■ Free-floating ball</li> <li>■ Antistatic design</li> <li>■ Blow-out proof valve spindle</li> <li>■ Self-relieving valve seats</li> <li>■ Opening and closing direction marked on lever handle</li> <li>■ Quarter-turn of lever handle opens/closes</li> <li>■ Locking pin limits rotation angle of lever handle</li> <li>■ Bubble-tight shut-off</li> <li>■ Bidirectional flow with minimal pressure drop</li> <li>■ Hydrostatically tested</li> <li>■ Mounting holes for panel mounting</li> </ul>

1) For available versions, see dimensions from page 8

## Materials

### Wetted parts

Valve body and fittings, ball, valve stem	<ul style="list-style-type: none"> <li>■ Stainless steel 316L</li> <li>■ Duplex F51 (1.4462)</li> <li>■ Super Duplex F55 (1.4501)</li> <li>■ Hastelloy C276 (2.4819)</li> <li>■ Monel 400 (2.4360)</li> <li>■ Stainless steel 6Mo (1.4547)</li> <li>■ Alloy 625 (2.4856)</li> <li>■ Alloy 825 (2.4858)</li> </ul>
Ball valve seat <sup>1) 2)</sup>	<ul style="list-style-type: none"> <li>■ PEEK, temperature range: -55 ... +250 °C [-67 ... +482 °F]</li> <li>■ HTT (high-temperature thermoplastic), temperature range: -55 ... +315 °C [-67 ... +599 °F]</li> </ul>

### Non-wetted parts

Locking pin, screws	Stainless steel 316/316L
Lever handle	Stainless steel 316/316L, PVC coated

1) Other materials available on request

2) For the process version, additional compressed graphite 99 % is used (with certification for fire safety)

## Instrument version

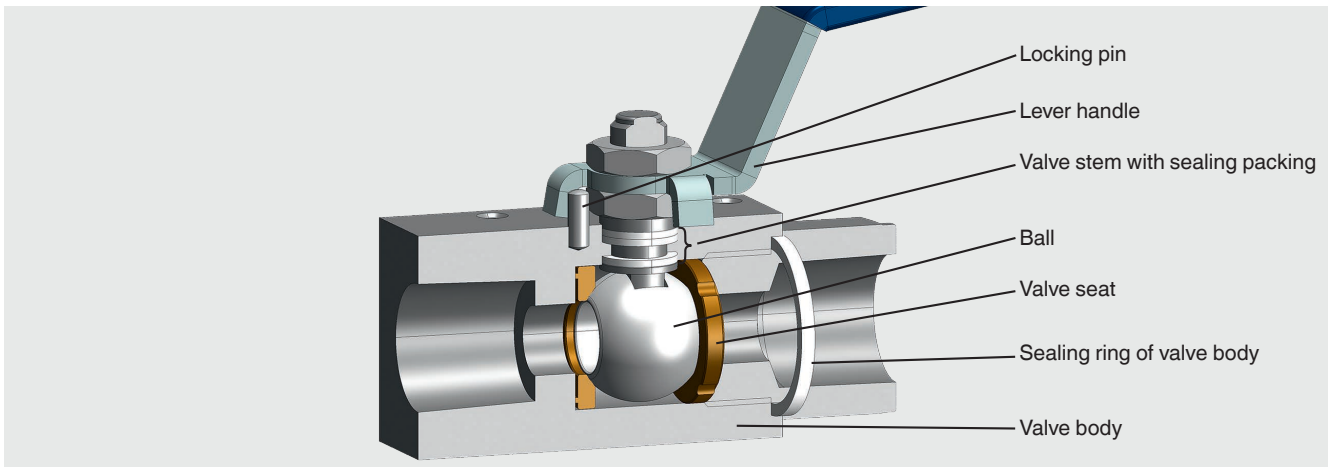

## Process version

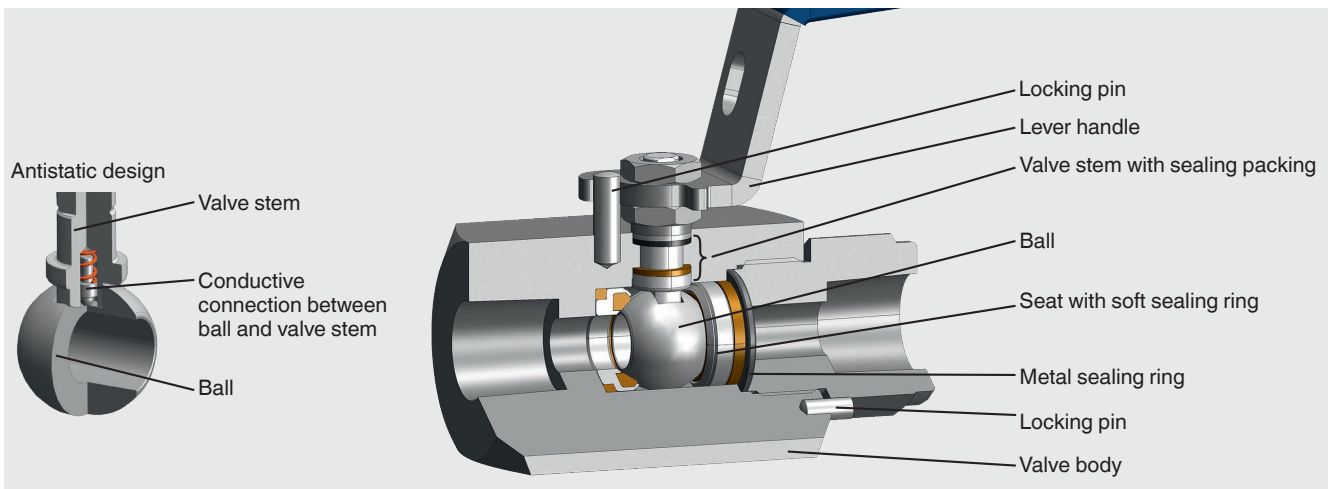

**Instrument version**

Round design

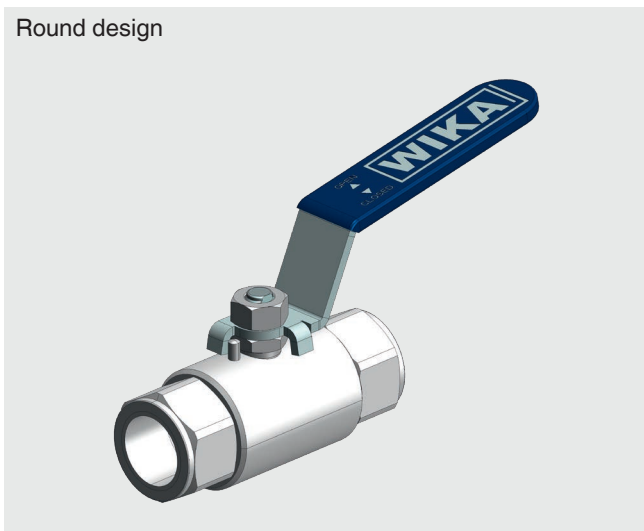

Square design, with mounting holes for panel mounting

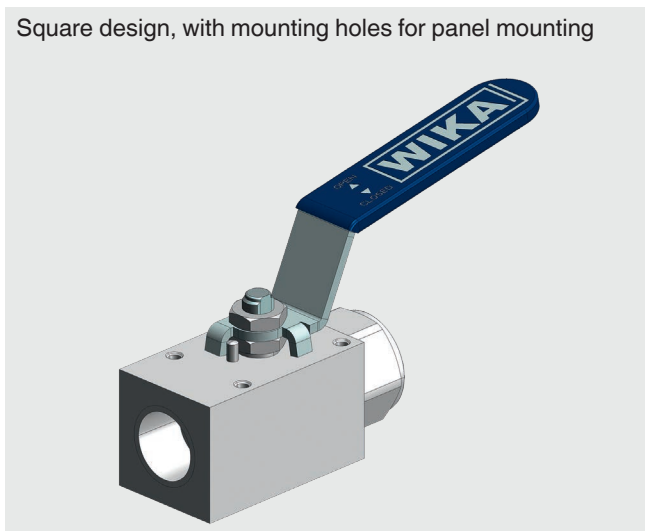

**Process version**

Square design

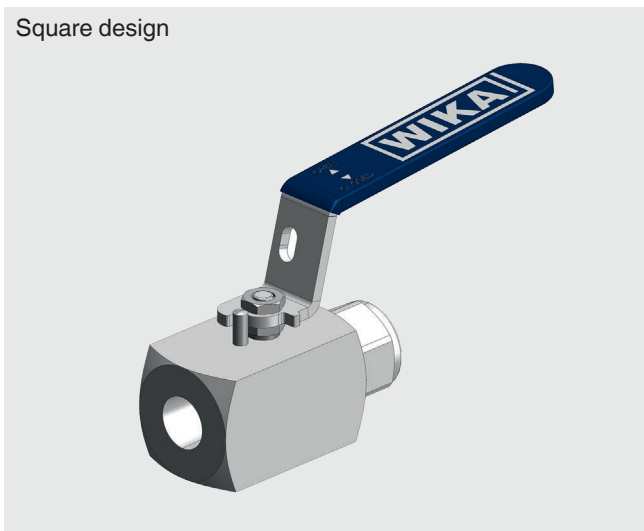

Multiport design

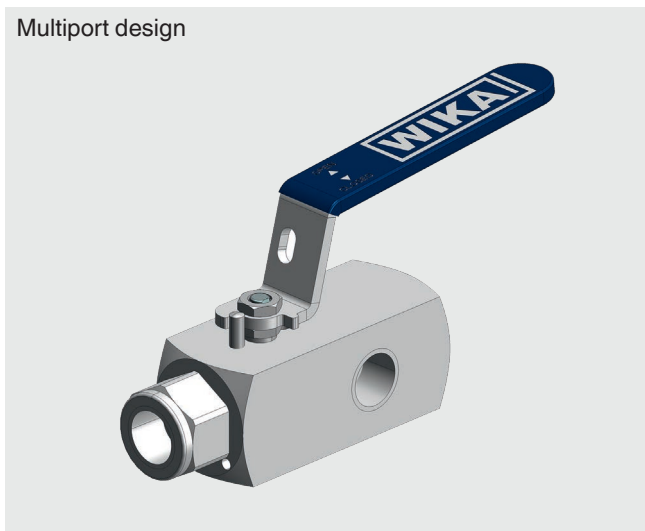

## Other versions

Anti-tamper version with padlock

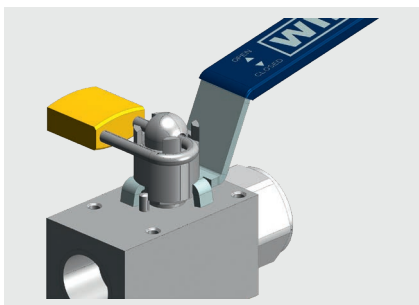

Extended valve body, suitable for flushing rings

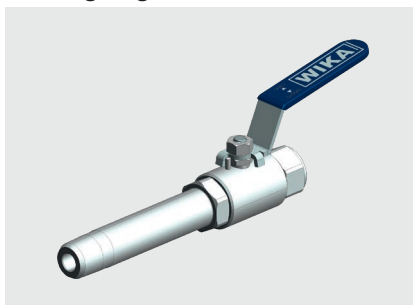

Mounting holes for panel mounting

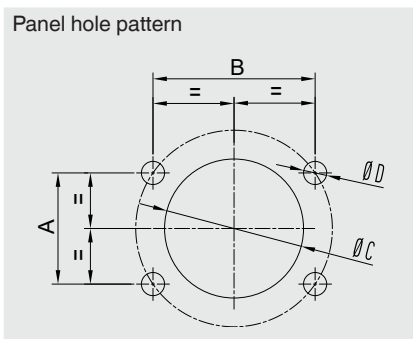
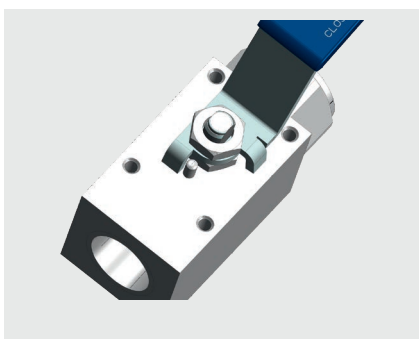

DN	Dimensions in mm [in]				
	A	B	C	D	Panel
¼"	24 [0.94]	35 [1.38]	30 [1.18]	5 [0.28]	3 [0.12]
⅜"	24 [0.94]	35 [1.38]	30 [1.18]	5 [0.28]	3 [0.12]
½"	24 [0.94]	35 [1.38]	30 [1.18]	5 [0.28]	3 [0.12]
¾"	46 [1.81]	50 [1.97]	45 [1.77]	7 [0.27]	3 [0.12]
1"	46 [1.81]	50 [1.97]	45 [1.77]	7 [0.27]	3 [0.12]

## Pressure-temperature diagram

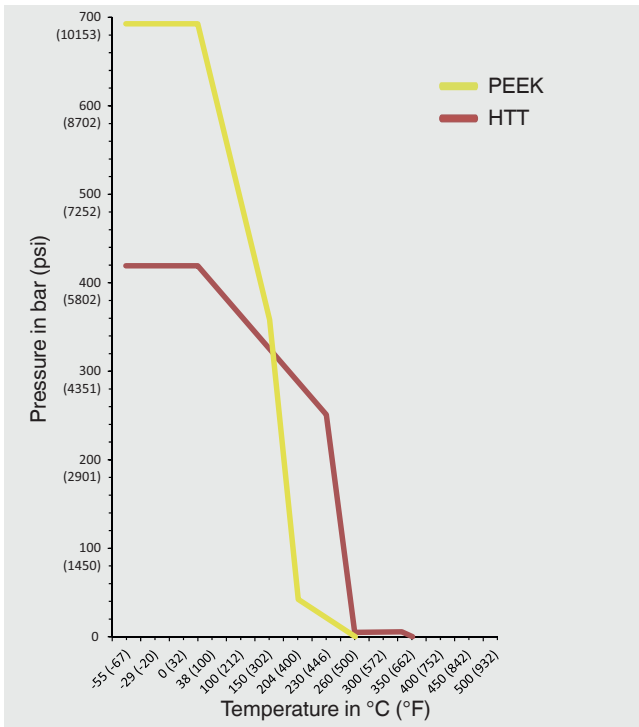

	Sealing material	Max. permissible operating pressure in bar at temperature in °C	Max. permissible operating pressure in bar at temperature in °C
Ball valve seat	PEEK <sup>1)</sup>	690 bar at 38 °C	10,000 psi at 100 °F
		276 bar at 250 °C	4,000 psi at 482 °F
	HTT (high-temperature thermoplastic)	420 bar at 38 °C	6,000 psi at 100 °F
		6 bar at 315 °C	87 psi at 599 °F

1) Polyetheretherketone

The minimum design temperature is -55 °C [-67 °F]. For permanently low operating temperatures of  $\leq -55$  °C [ $\leq -67$  °F] a special design is required.

## Approvals

Logo	Description	Country
	<b>EAC (option)</b> Machinery directive	Eurasian Economic Community

## Manufacturer's information and certifications

Logo	Description
-	<b>PMI <sup>1)</sup> test certificate (option)</b> All wetted parts
-	<b>Type tested for fire safety in accordance with API 607, ISO 10497, BS 6755-2 <sup>2)</sup></b>

1) Positive material identification

2) Valid only for process version ≤ 6,000 psi

## Certificates (option)

- 3.1 inspection certificate per EN 10204
  - Material certificate for all wetted parts per NACE MR0103/MR0175
  - Confirmation of pressure tests per API 598 <sup>3)</sup>

3) Shell test: 15 s test duration with 1.5 times the permissible working air pressure  
Seat test: 15 s test duration with 6 bar air/nitrogen

## Dimensions in mm [in]

Model BV, instrument version, round design, 3-part

Nominal pressure: 6,000 psi [413 bar]

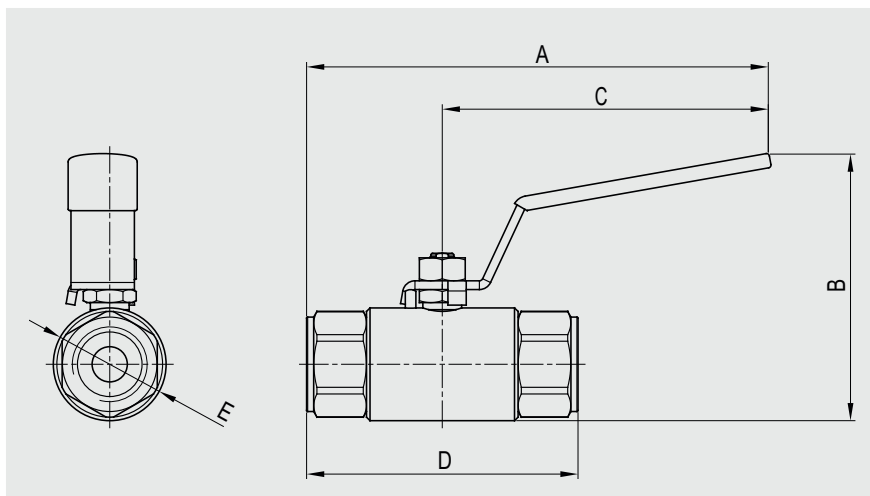

DN	Parts	Dimensions in mm [in]					
		Bore size	A	B	C	D	E
¼"	3	10 [0.394]	128 [5.039]	77 [3.031]	93 [3.661]	72 [2.835]	32 [1.26]
⅜"	3	10 [0.394]	128 [5.039]	77 [3.031]	93 [3.661]	72 [2.835]	32 [1.26]
½"	3	10 [0.394]	131 [5.157]	77 [3.031]	93 [3.661]	72 [2.835]	32 [1.26]
¾"	3	20 [0.787]	197 [7.756]	120 [4.724]	140 [5.512]	113 [4.449]	60 [2.362]
1"	3	20 [0.787]	200 [7.874]	120 [4.724]	140 [5.512]	119 [4.685]	60 [2.362]

Model BV, instrument version, round design, 2-part

Nominal pressure: 10,000 psi [690 bar]

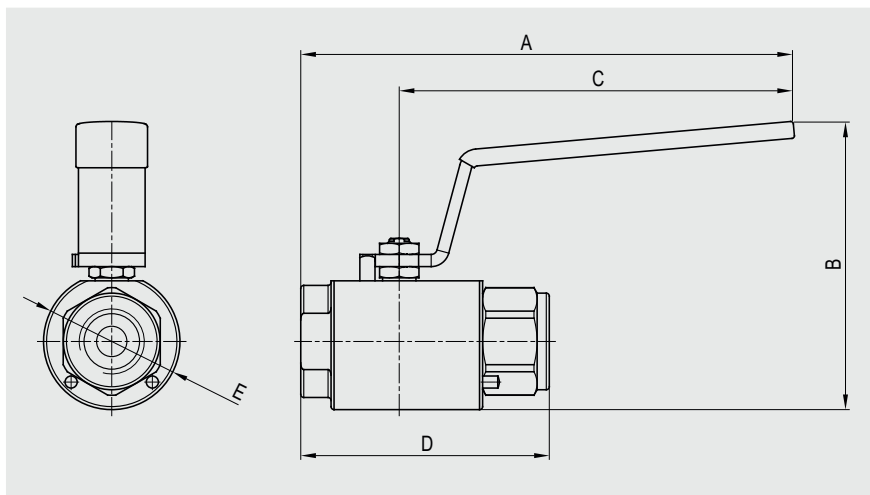

DN	Parts	Dimensions in mm [in]					
		Bore size	A	B	C	D	E
¼"	2	10 [0.394]	164 [6.457]	94 [3.701]	132 [5.197]	82 [3.228]	45 [1.772]
⅜"	2	10 [0.394]	164 [6.457]	94 [3.701]	132 [5.197]	82 [3.228]	45 [1.772]
½"	2	10 [0.394]	164 [6.457]	94 [3.701]	132 [5.197]	82 [3.228]	45 [1.772]



**Model BV, instrument version, square design**

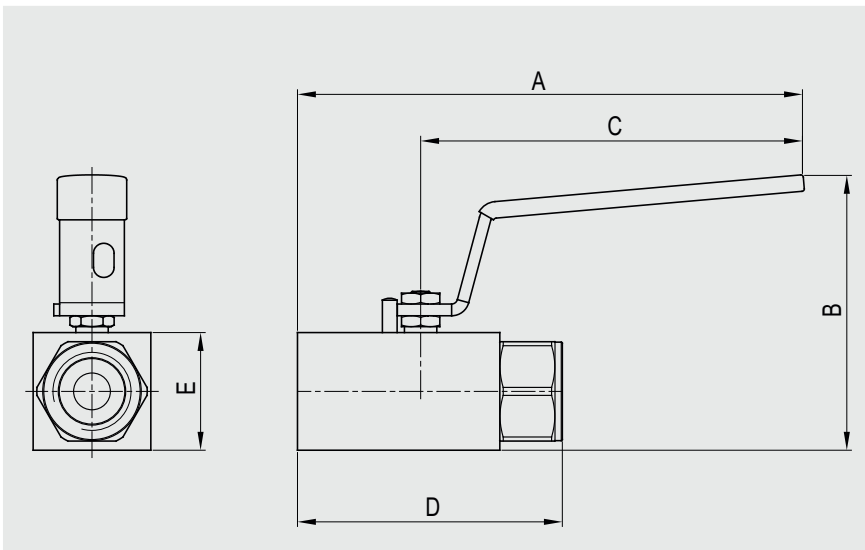

**Nominal pressure: 6,000 psi [413 bar]**

DN	Parts	Dimensions in mm [in]					
		Bore size	A	B	C	D	E
¼"	2	10 [0.394]	122 [4.803]	77 [3.031]	93 [3.661]	65 [2.559]	32 [1.26]
⅜"	2	10 [0.394]	122 [4.803]	77 [3.031]	93 [3.661]	65 [2.559]	32 [1.26]
½"	2	10 [0.394]	127 [5]	77 [3.031]	93 [3.661]	72 [2.835]	32 [1.26]
¾"	2	20 [0.787]	188 [7.402]	120 [4.724]	140 [5.512]	104 [4.094]	60 [2.362]
1"	2	20 [0.787]	190 [7.48]	120 [4.724]	140 [5.512]	110 [4.331]	60 [2.362]

**Nominal pressure: 10,000 psi [690 bar]**

DN	Parts	Dimensions in mm [in]					
		Bore size	A	B	C	D	E
¼"	2	10 [0.394]	164 [6.457]	94 [3.701]	132 [5.197]	82 [3.228]	40 [1.575]
⅜"	2	10 [0.394]	164 [6.457]	94 [3.701]	132 [5.197]	82 [3.228]	40 [1.575]
½"	2	10 [0.394]	164 [6.457]	94 [3.701]	132 [5.197]	82 [3.228]	40 [1.575]

**Model BV, process version, square design**

Nominal pressure: 6,000 psi [413 bar]

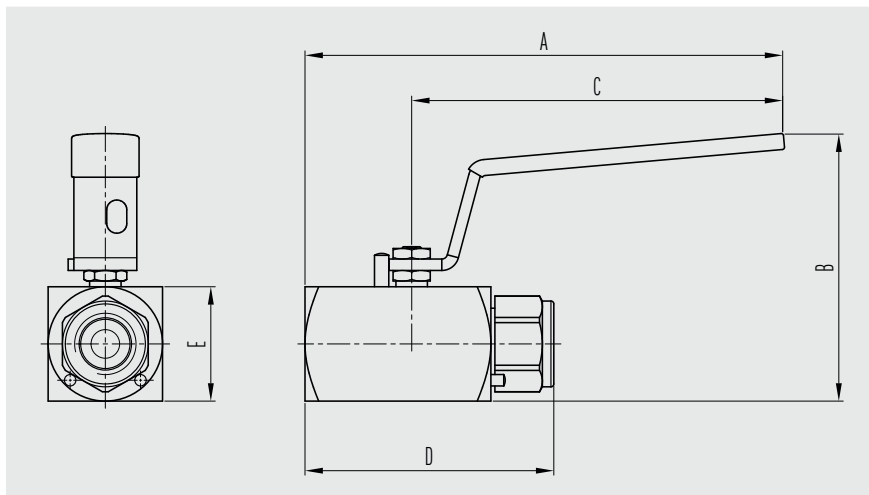

DN	Parts	Dimensions in mm [in]					
		Bore size	A	B	C	D	E
¼"	2	10 [0.394]	164 [6.457]	94 [3.701]	132 [5.197]	82 [3.228]	40 [1.575]
⅜"	2	10 [0.394]	164 [6.457]	94 [3.701]	132 [5.197]	82 [3.228]	40 [1.575]
½"	2	10 [0.394]	168 [6.614]	94 [3.701]	132 [5.197]	87 [3.425]	40 [1.575]

**Model BV, multiport design**

Nominal pressure: 6,000 psi [413 bar]

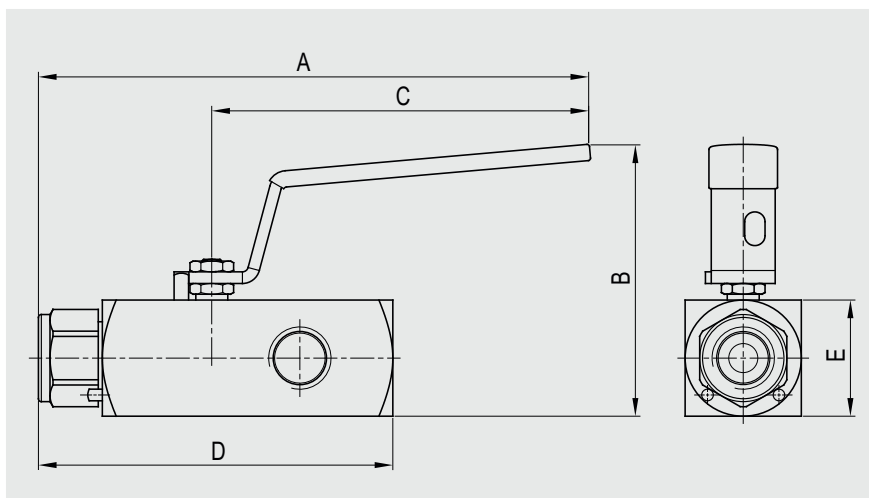

DN	Parts	Dimensions in mm [in]					
		Bore size	A	L	C	D	E
½"	2	10 [0.394]	182 [7.165]	94 [3.701]	132 [5.197]	117 [4.606]	40 [1.575]

## Ordering information

Model / Version / Nominal pressure / Nominal width (DN) / Options

© 05/2020 WIKA Alexander Wiegand SE & Co. KG, all rights reserved.  
The specifications given in this document represent the state of engineering at the time of publishing.  
We reserve the right to make modifications to the specifications and materials.



**WIKAL Alexander Wiegand SE & Co. KG**  
Alexander-Wiegand-Straße 30  
63911 Klingenberg/Germany  
Tel. +49 9372 132-0  
Fax +49 9372 132-406  
info@wika.de  
www.wika.de